



Automatic Weather Station AWS 2700

A rugged self-contained station suited for use in remote places without electricity supply. Data can be recorded on site or be transmitted in real-time.

Advantages:

- Compact modular design
- Self-contained
- Rugged construction
- Flexible configurations
- Standardized sensor outputs
- Low power consumption
- Long-term unattended operation
- Real-time or on-site data storage
- Selectable recording intervals
- Automatic transmission of data
- Plug-in communication solutions
- Mast height: up to 10 meters
- Easy installation and rising of a 10-meter mast; only one person required
- Low maintenance

The Automatic Weather Station 2700 consists of light, compact units in hard anodized aluminum which are quick and easy to install.

Sensors and the communication solution are fitted on a sensor cross arm placed on top of the mast. The mast is supported by a freestanding cabinet which is bolted to the ground. A hinge at the base of the cabinet facilitates raising and lowering of the station.

Standardized cables connect the Datalogger to the sensors, and to the optional radio transmitter and/or solar cell power module if these are installed. The station is supplied with a tool kit and a CD containing operating manuals and other documentation.

All Aanderaa SR10 sensors are read in selectable intervals by an 11-channel SmartGuard Datalogger located in the Cabinet. The raw

data read from the sensors are converted to engineering units and stored in the Datalogger. In addition to the SR10 sensors the SmartGuard can also read serial, digital and analog sensors. The SmartGuard is designed for ease of integration of new and existing sensor technologies into a single Aanderaa observatory node with modern self-describing XML data output formats.

Real-time output of data can be accomplished with one of our communication systems listed on the next page. The data is also stored on a removable SD-card inside the logger for backup.

The station has a low power consumption and can be powered by batteries, by mains AC power through an AC/DC Adapter, by a solar power pack.

Communication and illustrations

Communication solutions:

- UHF/VHF radio transmission. Real-time data
- GSM or analog modem. Programmable dial-up
- GPRS
- Radio Modem
- Argos Satellite
- Iridium Satellite selectable two-way communication
- TCP/IP communication, wired or wireless

Communication solutions can be changed according to project requirements



UHF Radio



Radio Modem



GPRS



Sensor cross arm

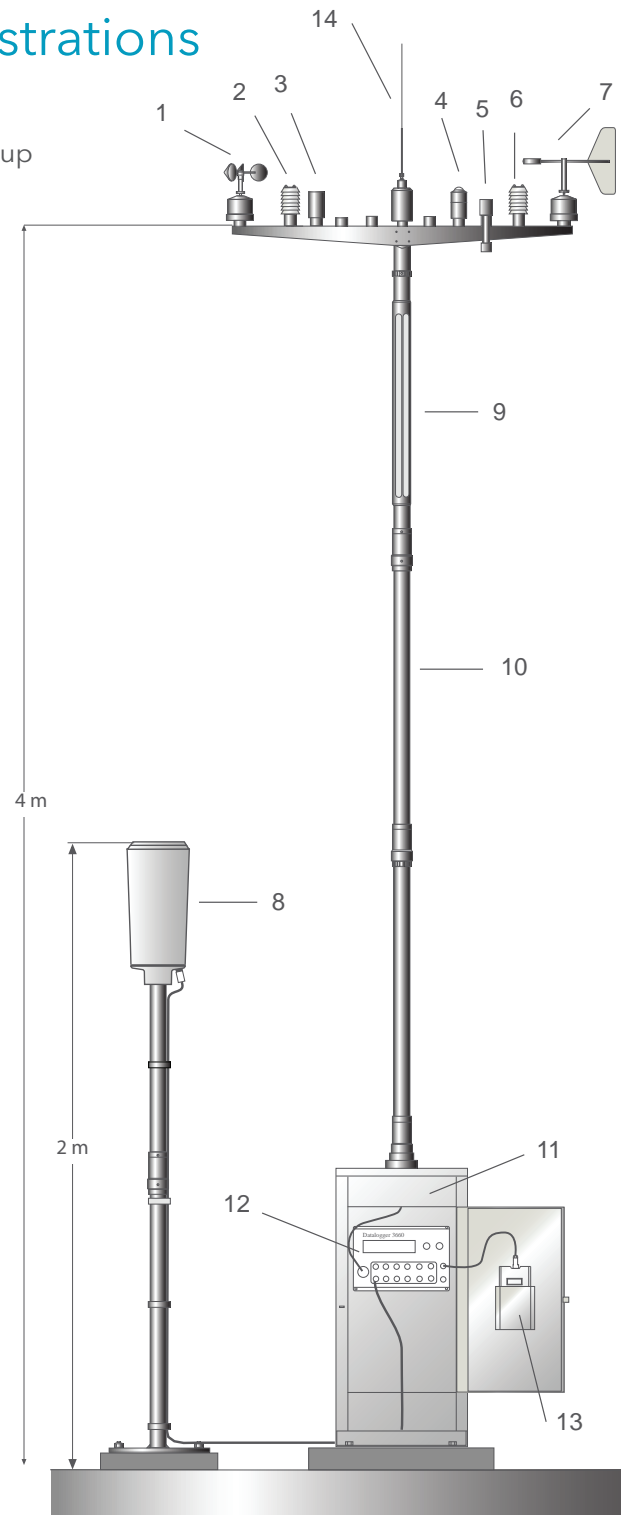

Please refer table on next page for details and part numbers.

Component List 2700

	Name	Specifications	
	Sensor Cross Arm 3415: up to 10 sensors and Radio Transmitter, Sensor Cross Arm 3435: up to 6 sensors and Radio Transmitter		
1	Wind Speed 2740: Two output signals: average wind speed and wind gust. Output signal: SR10. For more information see data sheet D151.	Range: Accuracy:	0 to 79m/s ±2% of reading
2	Air Temperature 3455: Output signal: VR22. For more information see data sheet D276.	Temp range: Resolution: Accuracy:	-43 to +48°C 0.1°C ± 0.1°C
3	Air Pressure 2810: Output signal: VR22. For more information see data sheet D161.	Range: Accuracy: Resolution:	920 - 1080hPa ±0.2hPa 0.2hPa
4	Net Radiation 2811: The direct and scattered solar radiation is measured as well as thermal radiation from the earth and the atmosphere. No shading screen is needed. Output signal: VR22. For more information see data sheet D169.	Wave Length: Accuracy:	0.3 -60 microns ±1% of full scale
5	Mira Visibility 3544: Measuring fog, haze, mist, dust and smoke. It will also detect reduced visibility caused by snow. For more information see data sheet D294.	Range:	20 - 3000m
6	Relative Humidity 3445: Output signal: SR10. For more information see data sheet D271.	Range: Accuracy:	0-100% RH ± 2%RH
7	Wind Direction 3590: Output signal : SR10. For more information see data sheet D300.	Threshold Speed: Accuracy:	< 0.3m/s ±5°
8	Rainfall 3864: Output signal: SR10, also available with heating, part no. 3864H. Mounted on Tube with Base Plate 3285 and Extension Tube 3776. For more information see data sheet D327.	Range: Accuracy: Funnel:	200mm/interval 12mm/min. max ± 2% 200cm
	Other sensors: Solar Radiation 2770, Temperature sensor 3444, Road Condition sensor 3565, Road Temperature sensor 3304, Water Level/ Temperature sensors 3791/3791S, Doppler Current sensor 4100 and other submersible sensors.		
10	Mast Section 2772 (hard anodised aluminum): Standard station is 4 meters high. The mast can be increased to maximum 10m by adding more mast sections. We recommend guy wires on masts higher than 4 meters or if severe weather conditions are expected.		
11	Cabinet 4720 (aluminum coated with polyester powder RAL7032) with cone for mast and hinged base.		
12	SmartGuard: Connecting Cable 5235. For sequential reading of Aanderaa sensors with SR10 or VR22 outputs. Input signals from sensors are routed through standardized connecting cables. Sampling intervals are user selectable from 0.5 to 180 minutes. Stored data can be collected via modem or by a portable PC. An LCD shows data in engineering units. For more information see data sheet D401.		
14	UHF/VHF Radio. Other available communication solutions: GSM, GPRS, Radio Modem, Argos Satellite, Iridium Satellite, TCP/IP or custom solution.		
	New Real-Time Collector data collection software and GeoView display software for storage and display of real-time data. For more information see brochure B174.		
	Typical AWS Applications: stand-alone weather stations, road monitoring systems, vessel traffic systems (VTMS), ports and harbours, other combined Hyd/Met systems		

Numbers in the left column refer to drawing on page 2 of this data sheet.

Applications and Software

Typical application areas:

- Extreme environment monitoring
- Stand-alone weather stations
- Roadside weather monitoring systems
- Vessel traffic systems (VTMS), marine weather
- Ports and harbours ocean/met systems
- Other combined Hyd/met systems
- Oil terminals and platforms requiring explosion proof sensors

Real-time data transmission:

The data can be received in real time via LAN, USB or serial connections such as VHF/UHF Receiver or modem.

Transmission of stored data:

The stored data can be downloaded from the SD-card or by connecting a PC directly to the Datalogger.

NEW real-time data presentation and visualization:

The Real-Time Collector 4807 receives data from the AWS 2700 and other Aanderaa equipment, and presents it to client programs on a uniform, well documented format. Client programs can be custom programs, or the Aanderaa GeoView display program which stores the data in an SQL database and presents it on a web page that can be viewed in any browser from computer in your local network, or published on the Internet.

More information and live data:

Please visit our home page: <http://www.aanderaa.com>
Here you will find more information about Aanderaa and our products, you will also find links to web pages showing live data from AWS 2700 stations and other Aanderaa equipment.

Maintenance

The Automatic Weather Station is designed to require a minimum of maintenance. All sensors are factory calibrated.

Packing

The Automatic Weather Station is shipped on a pallet. The package size of a standard 4m AWS (with 3 mast sections) is 120x80x75cm, and the weight is approximately 80 kilograms.



Visit our Web site for the latest version of this document and more information
www.aanderaa.com

Aanderaa is a trademark of Xylem Inc. or one of its subsidiaries.
© 2012 Xylem, Inc. D152 November 2012

Aanderaa Data Instruments AS
Sanddalsringen 5b, P.O. Box 103 Midtun,
5843 Bergen, Norway
Tel +47 55 60 48 00
Fax +47 55 60 48 01